

# **Master Time Clock**

**MTC-200**

**MTC-400**

**MTC-600**

**Users Manual**

**MidWest Time Control, Incorporated**  
P.O. Box 1108 Owasso, Oklahoma 74055  
Phone (918)272-9430 FAX (918)272-9441

[www.midwest-time.com](http://www.midwest-time.com)  
EMAIL: [sales@midwest-time.com](mailto:sales@midwest-time.com)

# TABLE OF CONTENTS

<u>TOPIC</u>	<u>PAGE</u>
GENERAL DESCRIPTION	1
INSTALLATION	1
FRONT PANEL CONTROLS	2
PROGRAMING	3
1. Set UP	3
2. Security Access Code	3
3. Set Current Time & Date	4
4. Set Holiday Schedule	4
5. Output Circuit Programing	4
6. Review & Cancel	6
7. Bulk Memory Erase	7
8. Daylight Savings Time	7
9. Memory Full	8
10. Lamp Test	8
11. Baud Rate Selection	8
EQUIPMENT WARNING	8
SECONDARY CLOCK CONTROL	8
1. Synchronous Wired Secondary Clocks	8
2. Minute Impulse Secondary Clocks	10
MAINTENANCE	10
SPECIFICATIONS	11
OPTIONAL EQUIPMENT	11

Copyright 2000 by MidWest Time Control, Incorporated. All rights reserved. No part of this publication may be reproduced, stored in a retrieval system, or transmitted in any form or by any means without the prior written permission of MidWest Time Control, Incorporated. While every precaution has been taken in the preparation of this publication, MidWest Time Control, Incorporated assumes no responsibility for errors or omissions. Neither is any liability assumed for damages resulting from the use of the information contained herein.

## GENERAL DESCRIPTION

The MTC Series is a Micro-Processor based line of Master Time Clocks and Programed Controllers. The unit will provide synchronization for a wide variety of industry standard secondary wall clocks, payroll recorders, time & date stamps, and other time keeping devices.

The MTC-200 has two output relay circuits, the MTC-400 has four circuits and the MTC-600 has six circuits.

The output circuits may be individually programed for control of bells, lights, heating and air conditioning, and other devices which can be scheduled for operation based on the time and day. Programing for these circuits may be TIME ON - TIME OFF or TIME ON - DURATION. Programing can be by individual day, 5 day (Mon.-Fri.), or 7 day.

The clock time base, in normal operation, is synchronized with the 60 Hz AC power line. During power failures, the time base is accurately maintained by a back up battery powered oscillator. The back up battery system uses a lithium energy cell with a design life of ten years. The battery maintains timing and circuit programing during a loss of primary power.

Holidays may be programed 12 months in advance. The Holiday feature will inhibit the automatic operation of the Output Circuits during a programed holiday.

Automatic daylight savings time changes. (May be turned off or set to new dates.)

Automatic updating of Impulse secondary clocks after a power failure. The MTC Series records the time of power failure and the current time. When power is restored, correction pulses are sent to the clocks.

All operator programing functions are easily performed from the front panel. A security access code and cabinet lock prevent unauthorized programing changes.

## INSTALLATION

1. As you unpack the clock, check for shipping damage to the carton or clock. Report any damage to the carrier.
2. The MTC series enclosure is designed for surface mounting with three punched mounting holes in the back panel. The outer enclosure door is removed by opening and lifting the door on the hinge pins. The control panel may be opened by releasing two quarter turn fasteners at the RH side. The Control Panel may be removed by disconnecting the J1 and J2 connectors, and removing three screws securing the control panel to the hinge. This exposes the enclosure mounting holes at the top corners and the bottom middle. The Back Plate may be removed, if necessary, by removing the four nuts securing the back plate to the enclosure. Dimensions for the enclosure mounting holes are shown in Figure 1. The unit may be semi-flush mounted to the depth shown in figure 1. The MTC series may be adapted for semi-flush mounting, in preexisting enclosures, by using the optional Semi-Flush Mounting Kit.

3. Knock-outs for 1/2" and 3/4" conduit fittings are located on the enclosure top, bottom and rear panels. The clock must be installed in accordance with all local wiring codes. The chassis ground connection must be connected to a good earth ground circuit. The terminal strips provided for external wiring connections are a pressure plate type, the terminals are rated for clamping two 12 ga. wires.
4. Synchronous Wired Secondary Clocks: A typical connection for 120 VAC or 24 VAC synchronous wired clocks is shown at Figure 2. Figure 3 shows a wiring method for correcting clocks of both voltages simultaneously using the optional Relay Kit.
5. Impulse Secondary Clocks: Note; Control of Impulse Secondary Clocks requires use of the optional Impulse Kit. Figures 5 & 6 show typical connections.
6. Before applying power to the Master Clock, assure that all wire runs to and from the output circuits and clock correction circuits are not shorted or grounded.

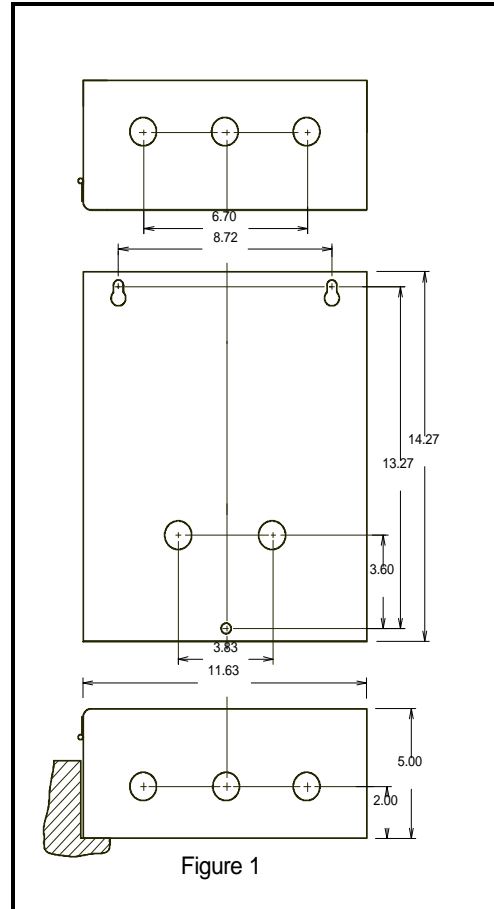

## FRONT PANEL CONTROLS

1. The **ENTER** button is used to enter selected data into the memory. This button is active in the program mode.
2. The **CANCEL** button is used in the review mode to cancel programed times and dates that are no longer needed. It is also used to exit the program mode and return the clock to normal operation.
3. The **AHEAD** and **BACK** buttons are used to increment the display to the time or date to be programed. They are also used in the Review mode to observe multiple programed times for the output circuits and multiple holidays. These buttons are active in the program mode.
4. The **MODE** button is used to select the functions to be programed or reviewed. An illuminated indicator will show the selected mode. Each time the MODE button is pressed, the next indicator in sequence will be illuminated. The Time Set function allows the setting of current time, day, month, date and year. The Holiday function allows setting of holiday dates. The Duration, On and Off modes are used to program the output circuits. The Erase mode is used to bulk erase all programed memory times and dates except the current time and date. The MODE button is active in the program mode.

5. The **REVIEW** button is used in conjunction with the MODE button to check the programmed times and dates. The review button is a push ON push OFF control, it must be turned OFF to advance the MODE function. It is active in the program mode.
6. The **SELECT** button is used with the mode function to program the month, date and year in the Time Set mode, and the beginning and ending month and date in the Holiday mode. The SELECT button is also used in the review mode to observe the beginning and ending dates of holidays. This button is active in the program mode.
7. The **CIRCUIT** button is used in the Duration, On and Off modes to select the output circuit to be programmed. It is active in the Duration, On and Off modes.
8. The **DAY** button is used in the On and Off modes to select the appropriate day or days for programming the output circuits. It is used in the Time Set mode to set the current day of the week.
9. The **IMPULSE SECONDARY CORRECTION** switch is used as an aid for initial synchronization of secondary impulse clocks. Placing the switch in the RAPID position causes the clocks to advance to the 58th or 59th minute at a rate of 30 steps per minute. Returning the switch to the OFF position returns control of the secondary clock to the Master. Placing the switch in the HR/MIN position causes the clocks to advance at the rate of 30 steps per minute until the switch is returned to the OFF position. This switch is active in the program Time Set mode. This switch must be in the OFF (center) position except while advancing the Impulse Secondary Clocks. (See Optional Equipment)
10. The **WIRE SYNC SECONDARY CORRECTION** switch is used as an aid for initial synchronization of secondary wired synchronous clocks. Placing the switch in the HOUR position sends one hourly correction signal to the secondary clocks. Placing the switch to the 12 HOUR position sends one 12 hour correction signal to the secondary clocks. Move the switch to OFF to return secondary clock control to the master. This switch is active in the program Time Set mode. This switch must be in the OFF (center) position except while advancing the Wired Synchronous secondary clocks.
11. The **CIRCUIT CONTROL** switches are provided for manual control of the output circuits. The OFF position turns the output circuit OFF regardless of the programming. The AUTO position places that output circuit under control of the program. The ON position places that output circuit ON regardless of the programming.
12. The **PROGRAM SELECT** switch (Optional) is a four position rotary switch for selecting one of four programs (A, B, C or D) for automatic control of the output circuits. Selecting a new program with this switch will transfer the unit control to that new program at the next minute transition. (See Optional Equipment)

## PROGRAMMING

### 1. SET UP

After the initial installation, the clock must be tailored for the desired operation. Open the Control Panel and note the 4 section selector switch in an opening at the upper LH corner of the control panel rear cover. The 12-24 switch selects the Control Panel display

format (12 or 24 hour). The 58-59 switch selects the timing sequence for Impulse Secondary clocks. The 12H IMP switch selects the timing sequence for 12 hour correction of minute impulse secondary clocks (see Minute Impulse Secondary Clock Correction section). The DST switch enables or disables the automatic correction of daylight savings time. Set this switch to DST if automatic correction is desired.

## 2. SECURITY ACCESS CODE

A Security Access Code must be entered before a time set, a program change, addition or review. The code is a simple and easily remembered front panel button sequence (ENTER, BACK, CANCEL and AHEAD). When these buttons are pressed in the correct sequence, the Program Control indicator will illuminate. Program changes can be made any time the program control indicator is illuminated. To leave the Program mode, press the CANCEL button. This restores the unit to normal operation. The Program Control mode will time out automatically 90 seconds after the last button is pressed. This prevents leaving the clock unattended in the program mode. The Program Control indicator must be illuminated during all programming operations.

In cases where the Security Access Code is not required or desired, it may be defeated as follows; press the following front panel buttons, in sequence; (ENTER, BACK, CANCEL and CIRCUIT). All front panel indicators except circuit status will illuminate. Press the CANCEL button. The security access code is now defeated. To enter the program mode, press the MODE button.

To reset the Security Access Code, press the following front panel buttons, in sequence; (ENTER, BACK, CANCEL and SELECT). All front panel indicators except circuit status will illuminate. Press the CANCEL button. The security access code is now reset.

**Note:** All Master Clocks are shipped from the factory with the security access code active.

For units equipped with the RS232-COM or RS232-WWV Options, the program mode may not be accessed while the unit is communicating with a remote device.

## 3. SET CURRENT TIME & DATE

**Note:** The AHEAD/BACK buttons reset the seconds counter to zero as the button is released. This feature can be used to accurately synchronize the Master Clock with other timekeeping devices.

STEP	PRESS	INDICATION	COMMENT
1		PROGRAM CONTROL	Enter Security Access Code
2	MODE	TIME SET	
3	AHEAD/BACK		Set Current Time (Note PM Ind)
4	SELECT	MONTH	
5	AHEAD/BACK		Set Current Month (1=Jan. 12=Dec.)
6	SELECT	DATE	
7	AHEAD/BACK		Set Cur. Date
8	SELECT	YEAR	
9	AHEAD/BACK		Set Cur. Year, 94=1994
10	DAY		Set Cur. Day of the week
11	CANCEL		Return to normal operation

#### 4. SET HOLIDAY SCHEDULE

**Note:** Each Holiday must be programmed with a beginning and ending month and date. Beginning and ending dates can not be the same.

STEP	PRESS	INDICATION	COMMENT
1		PROGRAM CONTROL	Enter Security Access Code
2	MODE	HOLIDAY, BEGIN, MONTH	
3	AHEAD/BACK		Set month of holiday (1=Jan. 12=Dec.)
4	SELECT	BEGIN, DATE	
5	AHEAD/BACK		Set date for first day of holiday
6	SELECT	END, MONTH	
7	AHEAD/BACK		Set month of holiday ending
8	SELECT	END, DATE	
9	AHEAD/BACK		Set date for first day of normal operation
10	ENTER		The display will blank momentarily
11	CANCEL		Return to normal operation

A total of ten holidays may be programmed by repeating steps 3 thru 10. All holiday starting and ending dates must be within the next twelve calendar months. Operation of the output circuits is inhibited During holidays.

For units equipped with the 4 Program Select Option, the holidays may be programmed at any program select position and is valid for all programs.

#### 5. OUTPUT CIRCUIT PROGRAMING

All output circuit programs entered will remain in the memory until cancelled.

All output circuits with a programmed ON time must have a programmed OFF time or DURATION.

For units equipped with the 4 Program Select Option, set the program selector to the desired program (A, B, C or D). The Duration Periods may be programmed at any Program Select Position and is valid for all position. The ON and OFF schedules for each program are independent and must be programmed with the program selector set to the proper position.

---

Assume circuit 1 is to ring a bell for 10 seconds Monday thru Friday at 8:00 AM, 12:00 Noon, and 4:00 PM.

STEP	PRESS	INDICATION	COMMENT
1		PROGRAM CONTROL	Enter security access code
2	MODE	DURATION	
3	CIRCUIT	CIRCUIT 1	
4	AHEAD/BACK		Set display to 10 (Range = 1-59 Sec.)
5	ENTER		Display will blank momentarily
6	MODE	ON	

7	DAY	MO,TU,WE,TH,FR	
8	AHEAD/BACK		Set time to 8:00 AM
9	ENTER		Display will blank momentarily
10	AHEAD/BACK		Set time to 12:00 Noon (PM Ind. ON)
11	ENTER		Display will blank momentarily
12	AHEAD/BACK		Set time to 4:00 PM
13	ENTER		Display will blank momentarily
14	CANCEL		Return to normal operation

---

Circuit 2 is to turn on a light at 7:45 AM Monday and off at 5:15 PM Monday.

1		PROGRAM CONTROL	Enter security access code
2	MODE	ON	
3	CIRCUIT	CIRCUIT 2	
4	DAY	MO	MO = Monday
5	AHEAD/BACK		Set time to 7:45 AM
6	ENTER		Display will blank momentarily
7	MODE	OFF	
8	CIRCUIT	CIRCUIT 2	
9	DAY	MO	
10	AHEAD/BACK		Set time to 5:15 PM
11	ENTER		Display will blank momentarily
12	CANCEL		Return to normal operation

---

Circuit 3 is to turn on the outside lights at 6:00 PM and off at 10:30 PM every day.

1		PROGRAM CONTROL	Enter security access code
2	MODE	ON	
3	CIRCUIT	CIRCUIT 3	
4	DAY	SU,MO,TU,WE,TH,FR,SA	
5	AHEAD/BACK		Set time to 6:00 PM
6	ENTER		Display will blank momentarily
7	MODE	OFF	
8	CIRCUIT	CIRCUIT 3	
9	DAY	SU,MO,TU,WE,TH,FR,SA	
10	AHEAD/BACK		Set time to 10:30 PM
11	ENTER		Display will blank momentarily
12	CANCEL		Return to normal operation

When programming multiple functions, step 1 is only necessary at the beginning of the first program and step 12 at the end of the last program.

## 6. REVIEW AND CANCEL

**Note:** Programed holiday dates and output circuit days and time may be cancelled while in REVIEW by pressing the CANCEL button while the date, day or time to be cancelled is displayed. Do not attempt to leave the program mode while the REVIEW Indicator is ON, the CANCEL button is used in the REVIEW mode to cancel programed dates and times. To leave the program mode when in REVIEW, press the REVIEW button to extinguish the REVIEW Indicator, then press the CANCEL button.

## REVIEW OUTPUT CIRCUIT PROGRAMING

STEP	PRESS	INDICATION	COMMENT
1		PROGRAM CONTROL	Enter security access code
2	MODE	DURATION	
3	REVIEW	REVIEW	
4	CIRCUIT	CIRCUIT 1, 2, 3, 4, 5, or 6	Any programed duration will be displayed Review off
5	REVIEW		
6	MODE	ON	
7	REVIEW	REVIEW	
8	CIRCUIT	CIRCUIT 1, 2, 3, 4, 5, or 6	
9	DAY	SU, MO, TU, WE, TH, FR, or SA	Programed ON times will be displayed for for each day. Multiple ON times may be checked by using the AHEAD or BACK button at each day. Review off
10	REVIEW		
11	MODE	OFF	
12	REVIEW	REVIEW	
13	CIRCUIT	CIRCUIT 1, 2, 3, 4, 5, or 6	
14	DAY	SU, MO, TU, WE, TH, FR, or SA	Programed OFF times will be displayed each day. Multiple OFF times may be checked by using the AHEAD or BACK buttons at each day. Review off
15	REVIEW		Review off
16	CANCEL		Return to normal operation

When reviewing the output circuit program, the scheduled event times are displayed in chronological order, not in the order programed.

## REVIEW HOLIDAYS

STEP	PRESS	INDICATION	COMMENT
1		PROGRAM CONTROL	Enter Security access code
2	MODE	HOLIDAY	
3	REVIEW	REVIEW, BEGIN, MONTH, DATE	Holiday Starting month and date is displayed
4	SELECT	END, MONTH, DATE	Holiday Ending month and date is displayed
5	AHEAD	BEGIN, MONTH, DATE	Next Holiday Starting month and date is displayed
6	SELECT	END, MONTH, DATE	Holiday Ending month an date is displayed
7	REVIEW		Review off
8	CANCEL		Return to normal operation

Repeating steps 5 and 6 will display all programed holiday beginning and ending dates.

*For units equipped with the 4 Program Select Option, the Duration Periods and Holiday Schedules may be reviewed and cancelled in any program select position and is valid for all positions. Reviewing and Cancelling ON and OFF schedules must have the Program Selector set to the desired program.*

## 7. BULK MEMORY ERASE

STEP	PRESS	INDICATION	COMMENT
1		PROGRAM CONTROL	Enter security access code
2	MODE	ERASE	
3	ENTER		The display will show :88 for approx. 5 seconds. The mode will revert to Time Set with the current time and day displayed. All user programed events will be erased except the current time, day and date.
4	CANCEL		Return to normal operation.

*For units equipped with the 4 Program Select option, the program to be bulk erased must be selected. Erasing program A will erase the Duration Periods and the Holiday Schedules. Erasing programs B, C or D has no effect on the Duration Periods or Holiday schedules.*

## 8. DAYLIGHT SAVINGS TIME CHANGE

**NOTE:** *The current legislated date for daylight savings time is factory programed. The date can not be reviewed. The MTC-200, MTC-400 and MTC-600 will automatically change at the current legislated day if the correct DAY, DATE, and TIME is set and the DST set up switch is ON.*

If the AC power is off during a scheduled daylight savings time change, the clock must be set to the new time using the Current Time and Day set procedure.

A special security access code is required to change the daylight savings time. The code is a four button sequence which must be entered in the correct order (ENTER, BACK, CANCEL, DAY).

**Note:** This procedure will override the factory programed dates.

STEP	PRESS	INDICATION	COMMENT
1		PROGRAM CONTROL BEGIN, MONTH	Enter special security access code
2	AHEAD/BACK		Set DST beginning month
3	SELECT	BEGIN, DATE	
4	AHEAD/BACK		Set DST beginning date
5	SELECT	END, MONTH	
6	AHEAD/BACK		Set DST ending month
7	SELECT	END, DATE	
8	AHEAD/BACK		Set DST ending date
9	ENTER		
10	CANCEL		Return to normal operation

Review user programed daylight savings time

1		PROGRAM CONTROL BEGIN, MONTH	Enter special security access code
2	REVIEW	REVIEW	
3	SELECT		Selects between beginning and ending dates of user programed daylight saving time
4	REVIEW		Return to DST Program Control
5	CANCEL		Return to normal operation

**Note:** User programed daylight savings time may be cancelled during this review procedure by pressing the CANCEL button.

## **9. MEMORY FULL**

An attempt to program times and dates in excess of the memory capacity will be indicated on the Display by a :99. This indication appears with the first program attempt in excess of the memory capacity.

## **10. LAMP TEST**

The lamp test is a method of turning on all of the front panel indicators except Circuit Status. This test provides a simple test to indicate proper circuit operation. Press the following front panel buttons in sequence; (ENTER, BACK, CANCEL & REVIEW). All front panel indicators except circuit status will illuminate. Press CANCEL, indicators will return to normal condition.

## **11. BAUD RATE SELECTION**

For units equipped with a communications port (RS232 or RS485 Options) the baud rate must be set. The available baud rate settings are 1200, 2400, 4800 and 9600. The rate set at the Master Clock must match that of the communicating device.

A special security access code is required to set the Baud Rate. The code is a four button sequence which must be entered in the correct order (ENTER, BACK, CANCEL, BACK).

When the access code is entered, the display will indicate the current Baud Rate. To change the Baud Rate, use the AHEAD button. When the desired rate is indicated, press the ENTER button.

## **EQUIPMENT WARNING**

Remote equipment controlled by this clock should have a warning sign to indicate that the equipment is remotely controlled. Primary power should be removed from that equipment prior to any maintenance or repair operations.

## **SECONDARY CLOCK CONTROL**

The MTC Series Master Time Clock controls and synchronizes a wide range of secondary clocks. It will control one variety of Minute Impulse Clocks and one variety of Synchronous Clocks simultaneously when equipped with the Optional Impulse Kit.

### **1. Synchronous Wired Secondary Clocks**

The MTC Series Master Clock will synchronize a variety of industry standard Synchronous Wired secondary clocks. The unit may be programmed by the user for the following clocks:

**Note:** The clock selection code is set to :00, at the factory.

CODE	CLOCK TYPE	CORRECTION
:00	MidWest Time	Hourly-8 Seconds @ XX:57:54, Twelve Hour-14 seconds 5:57:54
:01	Standard	Hourly-35 seconds @ XX:59:25, Twelve Hour-12 minutes @ 5:12:00
:02	Standard W/Aux.	Hourly-35 seconds @ XX:59:25, Twelve Hour-12 minutes @ 5:12:00 Run Motor power is removed from XX:59:00 to XX:00:00
:03	National Hourly	Hourly-35 seconds @ XX:00:00
:04	National 12 Hour	Hourly-25 seconds @ XX:00:00 Twelve Hour-25 minutes @ 6:00:00

To select the code, enter the special four button access code (AHEAD, CANCEL, BACK & ENTER) in that sequence. The Digital Display will indicate a two digit code number. With the AHEAD button, select the desired correction code, press ENTER. The unit will be restored to normal operation. The unit will automatically return to normal operation 90 seconds after the last button is pressed with the last code displayed on the digital indicator being the selected code.

Simplex, Cincinnati D10 and Cincinnati D12 wall clocks use Code :00.

- Code :01 Does not correct the second hand for these clocks.
- Code :02 Requires the use of the highest numbered output circuit. Place the Circuit Control switch for this circuit to the AUTO position.
- Code :03 The second hand on these clocks is not correctable.
- Code :04 The second hand on these clocks is not correctable.

Refer to figure 2 & 3 for Code :00, :01, :03 & :04 connecting diagram. Refer to figure 4 for Code :02 connecting diagram.

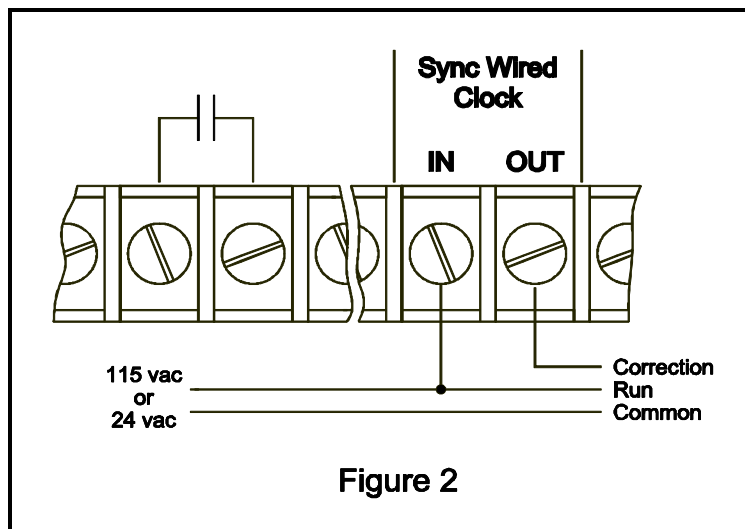

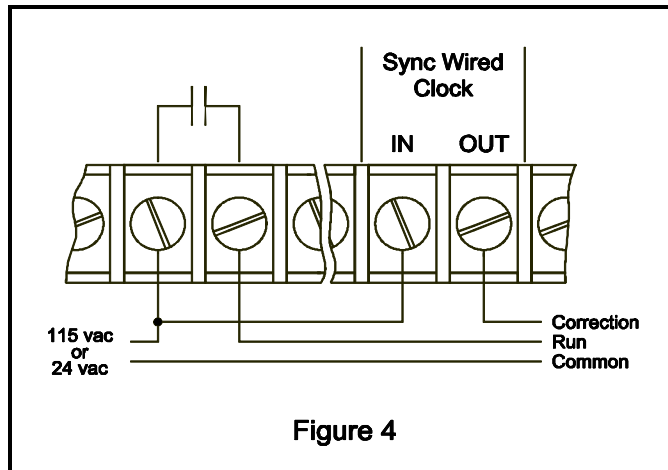
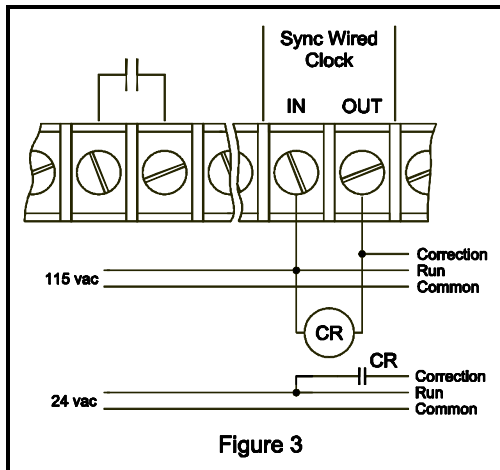

## 2. Minute Impulse Secondary Clocks

When equipped with the optional Impulse Kit the MTC Series Master Clock will operate and correct a wide variety of minute impulse clocks requiring a 24 VDC stepping pulse. The 58-59 and 12 HR IMP Set Up switches must be set properly. These switches are located on the back of the control panel in an opening at the upper LH corner.

- 58th Min. Type      24 VDC signal for 2 seconds at 58th second. Hourly correction for minute hand at 58th min. up to 10 minutes fast or 25 minutes slow between XX:49 and XX:58.
- 59th Min. Type      24 VDC signal for 2 seconds at 58th second. Hourly correction for minute hand at 59th min. up to 10 minutes fast or 25 minutes slow between XX:50 and XX:59.
- 12 HR IMP Type      This is a 59th Min. 2 Wire Reverse Polarity Type with 12 Hour Update capability. 24 VDC signal for 2 seconds at 58th second. Hourly Correction for minute hand. Hour hand is corrected two times each day between 5:00 and 7:00.

Refer to figure 6 for connection of 2 Wire Reverse Polarity Minute Impulse Clocks; (58th Min.), (59th Min.) or (59th Min. with 12 Hour Update).

Refer to figure 5 for connection of 3 Wire Minute Impulse Clocks: (58th Min.) or (59th Min.).

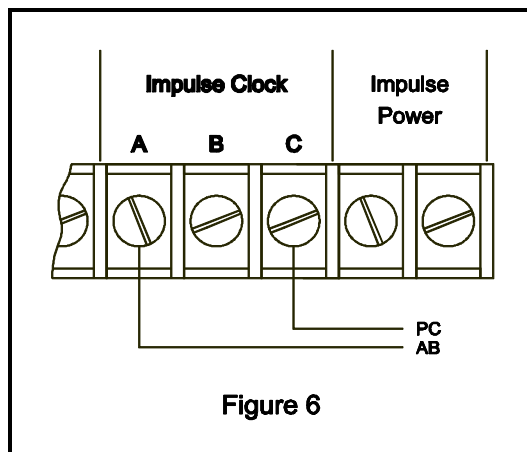
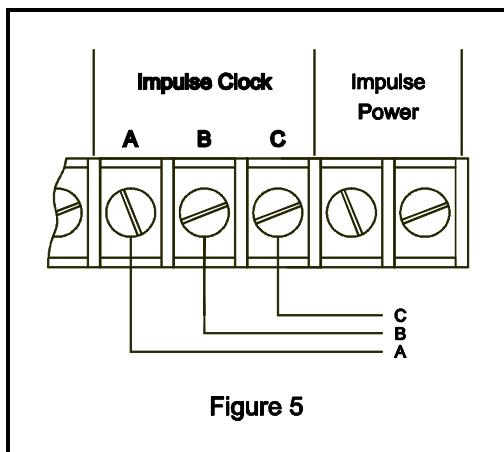

## MAINTENANCE

There are a limited number of field maintenance items in the MTC Series.

Input Power Fuse (Front Panel)	3 Amp. Littlefuse 312003 or Equiv.
Output Circuit Fuses (F1, F2, F3, F4, F5, & F6)	10 Amp. Littlefuse 312010 or Equiv.
Sync. Wired Correction Fuse (F7)	10 Amp. Littlefuse 312010 or Equiv.
Impulse Correction Fuse (F8)	4 Amp. Littlefuse 312004 or Equiv.
Impulse Relay	MidWest Time Control Part No. 530001-02

**Note:** The life of the Impulse Relays will be determined by the number of Impulse Clocks connected. At the rated contact load (10 Amp.), the relay contacts should last more than 1 year. The relays are socket mounted and may be easily replaced. The relays should be set up for scheduled replacement approximately once per year to avoid failure at an inopportune time.

**Back Up Battery:** The battery is a Lithium Energy Cell with a design life of 10 years. The symptoms of battery failure will be a loss of time or programing during a power failure. If this occurs, contact your dealer for replacement instructions.

## SPECIFICATIONS

Power requirements	115 VAC, 60 HZ, 15 Watts Max.
Program Capacity	650 Events (See Optional Equipment)
Holidays	10 Holidays (Holidays may be multiple days)
Operating Temp.	0 to 60 Deg. C
Storage Temp.	-30 to 75 Deg. C
Humidity	95% non-condensing
Weight	19.25 Lbs.

## OPTIONAL EQUIPMENT

**Impulse Kit** - Required for impulse clock correction. Provides a 4 Amp. power supply (Includes Impulse power transformer, Impulse Relays and mounting hardware)

**Semi-Flush Mounting Kit** - Adapts master clock for mounting in a preexisting 941 type enclosure. (Includes a new Enclosure Back Panel and Door)

**Relay Kit** - Used for auxiliary control functions or to expand capacity of the output circuit relays. Contacts are DPDT 10 Amp. rating. (May be ordered with 1 or 2 Relays)

**Four Program Option** - This options expands the program capacity to 2600 events divided into four 650 event programs (A,B,C & D). The programs are manually selected by a front panel switch. This is a factory installed option.

**Expanded Memory Option** - This option expands the program capacity from 650 to 2600 weekly events all in one program. This is a factory installed option.

**RS232-COM Communications Option** - This option provides a RS232 port and revised software. This port is used to communicate with a computer. The computer time is synchronized with the Master Clock. The output circuits may also be programed from the computer terminal. This is a factory installed option.

**RS485 Option** - This option provides a RS485 output port. This is a 2 wire communications port designed to communicate with MidWest Time Control's Digital clocks and to synchronize the time in multiple computer installations. This is a factory installed option.

The MTC Series of Master Clock is a microprocessor based unit controlled by software. It is a very versatile unit that can be adapted for a wide range of special applications. Consult your dealer or the factory for special requirements.

## WARRANTY

MidWest Time Control, Incorporated warrants the MTC Series Master Clock to be free of defects in materials and workmanship for a period of one year from the date of delivery to the purchaser. This period may be extended to one year from the date of delivery to a distributors vendee, however in no event will the warranty be extended for more than one year from the date of installation or two years from the date of shipment from the factory whichever is sooner.

We also warrant that if operated properly, the unit will operate within the advertised specifications for the stated warranty period. Excluded from this warranty are fuses and socket mounted relays. These are considered normal maintenance items.

The liability of MidWest Time Control, Incorporated under this warranty shall be limited to repairing or replacing a unit proved to be defective and returned to us with transportation charges prepaid within the stated warranty period.

This warranty is in lieu of all other warranties, express or implied and constitutes all of our liabilities to the purchaser or user. We assume no liability for consequential damages, for anticipated or lost profits, incidental damages or loss of time or other losses incurred by the purchaser, user or any third party in connection with the product covered by this warranty.

This warranty will be void for any product with defects which have been caused by abuse, neglect, improper installation, unauthorized repair or modification.

For return authorization under this warranty, contact;

Customer Service Department

MidWest Time Control, Incorporated  
P.O. Box 1108  
Owasso, Oklahoma 74055

Phone (918)272-9430  
FAX (918)272-9441

[www.midwest-time.com](http://www.midwest-time.com)  
EMAIL: [sales@midwest-time.com](mailto:sales@midwest-time.com)